

Drop Options

Canopi

Wave Shade dimensions and details

REVISIONS		
	MM/DD/YY	REMARKS
1	--/--/--	...
2	--/--/--	...
3	--/--/--	...
4	--/--/--	...
5	--/--/--	...

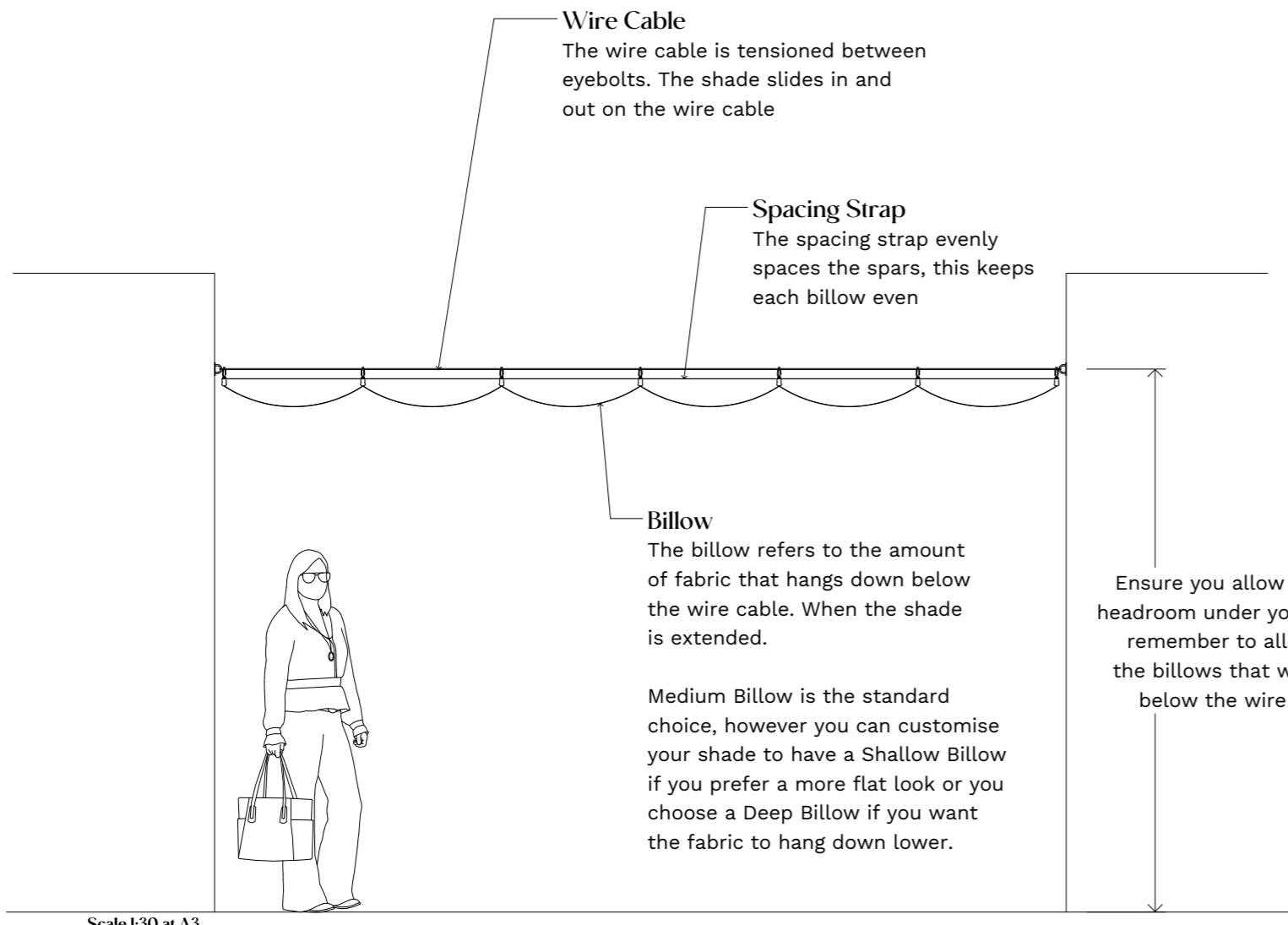

Scale 1:30 at A3

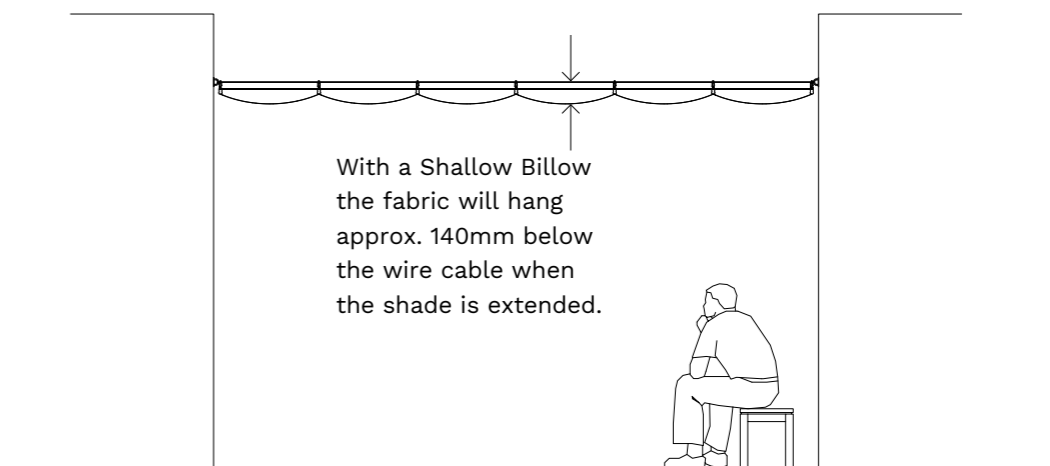

Scale 1:50 at A3

Shallow Billow

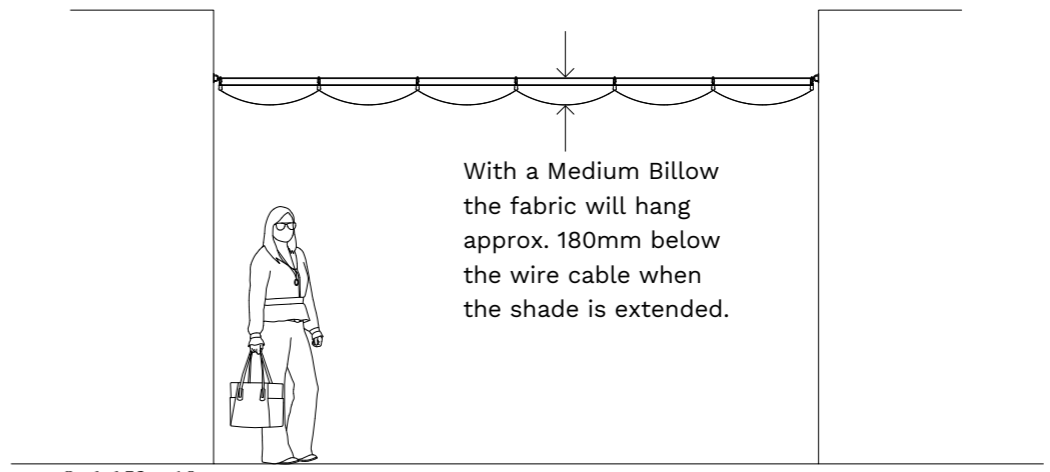

Scale 1:50 at A3

Medium Billow

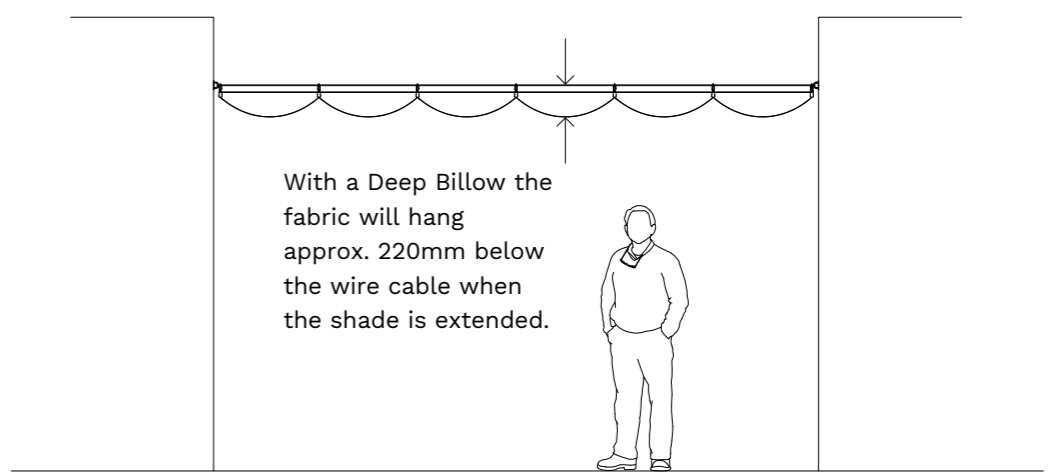

Scale 1:50 at A3

Deep Billow

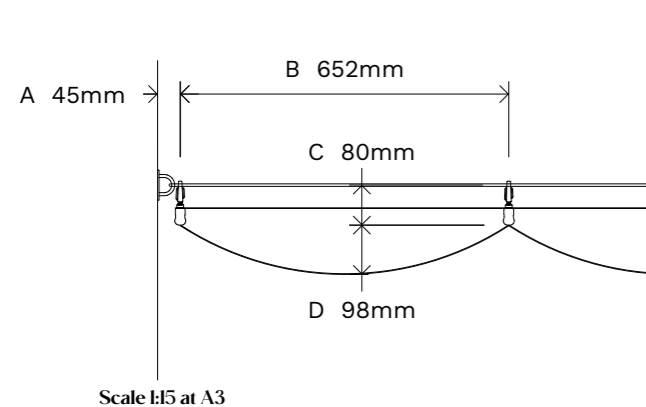

Scale 1:15 at A3

A is generally 45mm on all shades when using standard fixing eyes.

B is the spar spacing, this is a division of the total length of the shade less 90mm for the fixing eyes. In this case it is 652mm, but it will vary for every shade. See Drop Options on previous page for more detail.

C is always 80mm. This is the depth of the clip + spar

D is the depth of the fabric billow, this varies depending on measurement B and on the billow option chosen

Shallow D = 10% of B

Medium D = 15% of B

Deep D = 20% of B

Billow Options

Canopi

Wave Shade dimensions and details

REVISIONS		
MM/DD/YY	REMARKS	
1	---	...
2	---	...
3	---	...
4	---	...
5	---	...